

# A6500-RC System Relay Card

The 16-Channel Output Relay Module is designed for high reliability for the plant’s most critical rotating machinery. This monitor is used together with the AMS 6500 ATG to build a complete API 670 machinery protection monitor. Applications include steam, gas, compressors, and hydro turbo machinery.

Any channel clear, alert, or alarm signal can be selected as input to the 16-Channel Output Relay Module. Use Boolean logic, apply time delay, and select an output relay to complete the configuration. Easy-to-use software provides graphical logic displays that guide the user pictorially through configuration.

The AMS 6500 Machinery Health Monitor is an integral part of PlantWeb® and AMS software. PlantWeb provides operations - integrated machinery health combined with the Ovation® and DeltaV™ process control system. AMS software provides maintenance personnel advanced predictive and performance diagnostic tools to confidently and accurately determine machine malfunctions early.



A6500-RC

- 3U size, 2-slot plug-in module decreases cabinet space requirements in half from traditional 6U size cards.
- API 670 compliant, hot-swappable module.
- 66 inputs, 16 logic networks, 16 relay outputs.
- A6500-RC is a 10TE wide module for the A6500-SR rack.

Digital Input		
Number of Inputs	66	
Logic Low Level	0V to 3V	Not active
Logic High Level	13V to 32V	active
Open Input		Open input detect as not active
Rated Current	1 mA	
Rated Power	24 mW	

Relay Output		
Number of Outputs	16	
Type	SPDT	
Maximum Voltage Capacity	32V DC / 48V AC	
Output Load	AC1: 48V / 2A DC1: 32V / 2A DC-13: 24V / 1A AC-15: 24V / 2A	
Turn-on / Turn-off Time	10 ms NO contact 13 ms NC contact	Without logic processing time
Rated Current	2 A	
Rated Power	96 W	



Environmental, General		
Protection Class	IP 20, IEC 60529	
Conformal Coating	Airborne contaminants resistance	ISA-S71.04-1985 airborne contaminants class G3
	Material: HumiSeal® 1B31 EPA	According to IPC-CC-830B and IPC-A 610
Operating Temperature	-20°C to +70°C (-4°F to 158°F) with forced cooling -20°C to +55°C (-4°F to 131°F) without forced cooling	
Temperature for Storage and Transport	-40° to 85°C (-40° to 185°F)	
Relative Humidity	5–95%, non condensing	
Vibration	IEC 68-2, part 6 0.15mm, 10-55HZ 20m/s², 55-150Hz	
Shock	IEC 60068-2-27 150 m/s² 4000 shocks per axis	
EMC Resistance	EN50081-1 / EN50082-2	
Power Consumption	Max. 6W	
Configuration	Password protected	

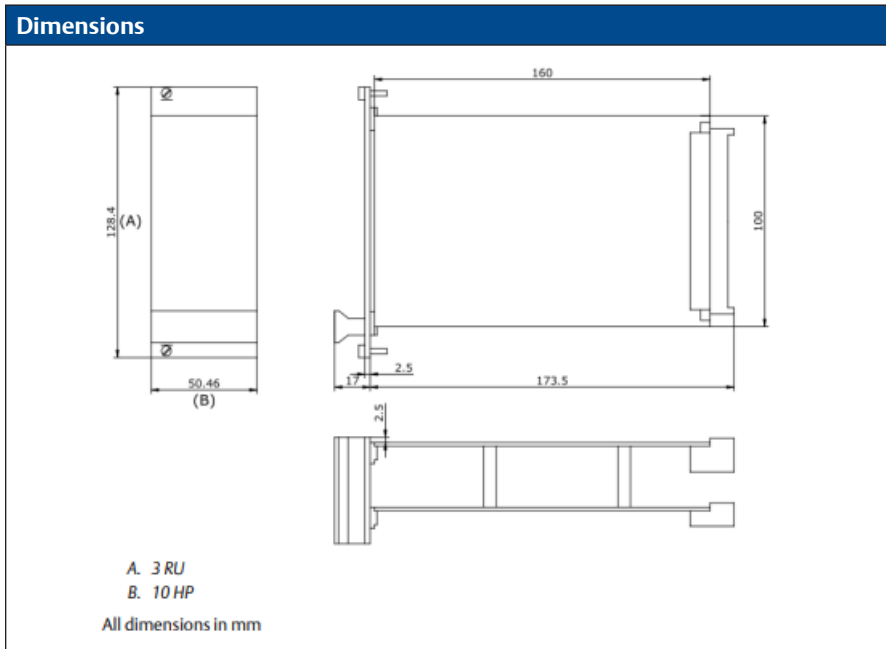

Compliance and Certifications	
CE	EMC – EN61326-1 2014/30/EU 2014/34/EU 2011/65/EU
ATEX	EN 60079-0:2012 EN 60079-15:2010
IEC-Ex CCOE PESO India	IEC 60079-0:2011; Edition: 6.0 IEC 60079-15:2010; Edition: 4
CSA	CAN/CSA-C22.2 NO. 0-10 CAN/CSA-C22.2 NO. 61010-1-12 CAN/CSA-C22.2 NO. 60079-0:15 CAN/CSA-C22.2 NO. 60079-15:12 IEC 60529:2013 + COR2:2015 UL 61010-1:12 UL 60079-0:13 UL 60079-15:13
EAC	TP TC 012/2011 ГОСТ 31610.0-2014 ГОСТ 31610.15-2014
CCC	GB 3836.1-2010 GB 3836.8-2014
Marine	DNV GL rules for classification – Ships and offshore units
Safety (SIL): SC 2 (SIL 2 Capable)	IEC 61508:2010 Parts 1-7

## Hazardous Area Approvals

Non-sparking nA in combination with nC	
ATEX	II 3G – Ex nA nC IIC Gc, $-20^{\circ}\text{C} \leq T_s \leq 70^{\circ}\text{C}$ (with $T_s \leq 70^{\circ}\text{C}$ the requirements for temperature class T4 are met)
IEC-Ex	II 3G – Ex nA nC IIC Gc, $-20^{\circ}\text{C} \leq T_s \leq 70^{\circ}\text{C}$ (with $T_s \leq 70^{\circ}\text{C}$ the requirements for temperature class T4 are met)
CSA	Class I Division 2, Groups A, B, C, D, T4 Class 1, Zone 2 Ex / AEx nA nC IIC T4 Gc (the ambient temperature within the end use enclosure shall not exceed $55^{\circ}\text{C}$ )
EAC-Ex	Ex nA nC IIC Gc,U $-20^{\circ}\text{C} \leq T_s \leq 70^{\circ}\text{C}$
CCC-Ex	Ex nA nC IIC Gc $-20^{\circ}\text{C} \leq T_s \leq 70^{\circ}\text{C}$
CCOE PESO India	Ex nA nC IIC T4 Gc, $-20^{\circ}\text{C} \leq T_s \leq 70^{\circ}\text{C}$ (with $T_s \leq 70^{\circ}\text{C}$ the requirements for temperature class T4 are met)
KTL Korea	Ex nA nC IIC $-20^{\circ}\text{C} \leq T_s \leq 70^{\circ}\text{C}$

## Ordering Information

Model Number	Product Description
A6500-RC	16-Channel Output Relay Module, 10 TE wide for use in A6500-xR rack

©2023, Emerson. All rights reserved.

The Emerson logo is a trademark and service mark of Emerson Electric Co. The AMS logo is a mark of one of the Emerson family of companies. All other marks are the property of their respective owners.

The contents of this publication are presented for informational purposes only, and while diligent efforts were made to ensure their accuracy, they are not to be construed as warranties or guarantees, express or implied, regarding the products or services described herein or their use or applicability. All sales are governed by our terms and conditions, which are available on request. We reserve the right to modify or improve the designs or specifications of our products at any time without notice.

### Contact Us

[www.emerson.com/contactus](http://www.emerson.com/contactus)